



WT32C3-S5 Datasheet

WIRELESS-TAG

V1.0.2

July 15, 2021

Wireless-Tag Technology Co., Ltd.



About this document

This document provides users with the technical specifications for WT32C3-S5.

Document updates

Please visit Wireless-Tag's official website to download the latest version of the document.

Revision history

Please go to the document revision history page to view the revisions of the document.

Disclaimer and copyright notice

Information in this paper, including URL references, is subject to change without prior notice.

This document is provided "as is" with no warranties whatsoever, including any warranty of merchantability, non-infringement, fitness for any particular purpose, or any warranty otherwise arising out of any proposal, specification or sample. All liability, including liability for infringement of any patent rights, relating to use of information in this document is disclaimed. No licenses, either express or implied, by estoppel or otherwise, to any intellectual property rights are granted herein.

All trade names, trademarks and registered trademarks mentioned in this document are property of their respective owners, and are hereby acknowledged.

Copyright © 2020 Wireless-Tag Technology Co., Ltd. All rights reserved.

Statement

Due to product version upgrade or other reasons, the contents of this manual may be changed. Wireless-Tag Technology Co., Ltd reserves the right to modify the contents of this manual without any notice or prompt. This manual is only used as a guide. Wireless-Tag Technology Co., Ltd makes every effort to provide accurate information in this manual, but it does not guarantee that the contents of the manual are completely free of errors. All statements, information and suggestions in this manual do not constitute any express or implied guarantee.

Revision History

No.	Version	Changes	Change (+/-) Descriptions	Author	Date
1	V1.0.0	C	Created the document	Fiona	January 13, 2021
2	V1.0.1	C	Updated pin definition	Fiona	June 15, 2021
3	V1.0.2	A	Added current consumption	Fiona	July 15, 2021

*Changes: C—create, A—add, M—modify, D—delete



Contents

1 Overview.....	1
2 Features.....	2
3 Hardware Specifications.....	3
3.1 Block Diagram.....	3
3.2 Pin Descriptions.....	3
3.3 Strapping Pins.....	4
4 Electrical Characteristics.....	7
4.1 Absolute Maximum Ratings.....	7
4.2 Recommended Operating Conditions.....	7
4.3 Current Consumption.....	7
5 Application Note.....	9
5.1 Module Dimensions.....	9
5.2 Reflow Profile.....	9
5.3 Module Schematics.....	10
5.4 Peripheral Schematic.....	10
6 Product Trial.....	12

1 Overview

WT32C3-S5 WiFi module is a low-power, cost-effective embedded wireless network control module, which is an ideal choice for smart grid, building automation, security system, smart home, telemedicine and other IoT applications.

The module's core processor ESP32-C3 integrates an industry-leading 32-bit RISC-V single-core microprocessor with a maximum clock speed of 160 MHz in a small-sized package. It comes with an on-board PCB antenna.

The module supports for the standard IEEE802.11 b/g/n protocol and Bluetooth Low Energy 5.0 (Bluetooth LE): Bluetooth 5, Bluetooth mesh. The module can be used to help Bluetooth pairing and network connection to existing devices, or build an independent network controller.

2 Features

- SMD-22 package
- On-board PCB antenna
- Operating voltage: 3.3V
- Operating ambient temperature: -20-85°C
- ESP32-C3 chip embedded, 32-bit RISC-V single-core microprocessor, up to 160MHz
 - SRAM 400KB
 - RTC SRAM 8KB
 - ROM 384KB
- Embedded Flash 4MB
- System
 - WIFI
 - IEEE 802.11 b/g/n protocol
 - 1T1R mode with data rate up to 150 Mbps
 - WIFI @2.4 GHz, support for WEP/WPA-PSK/WPA2-PSK security mode
 - Frame aggregation (TX/RX A-MPDU, RX A-MSDU)
 - BLE
 - Bluetooth Low Energy 5.0(Bluetooth LE): Bluetooth 5, Bluetooth mesh
 - Speed: 125 Kbps, 500 Kbps, 1 Mbps, 2 Mbps
 - Advertising Extensions
 - Multiple Advertisement Sets
 - Channel Selection Algorithm #2
 - Hardware
 - Support for GPIO, SPI, UART, I2C, I2S, infrared transceiver, LED PWM controller, USB JTAG interface, general DMA controller, TWAITM controller (compatible with ISO11898-1), temperature sensor, SAR ADC
 - Support for STA/AP/STA+AP mode
 - Support for remote OTA

3 Hardware Specifications

3.1 Block Diagram

Figure 1 Block Diagram

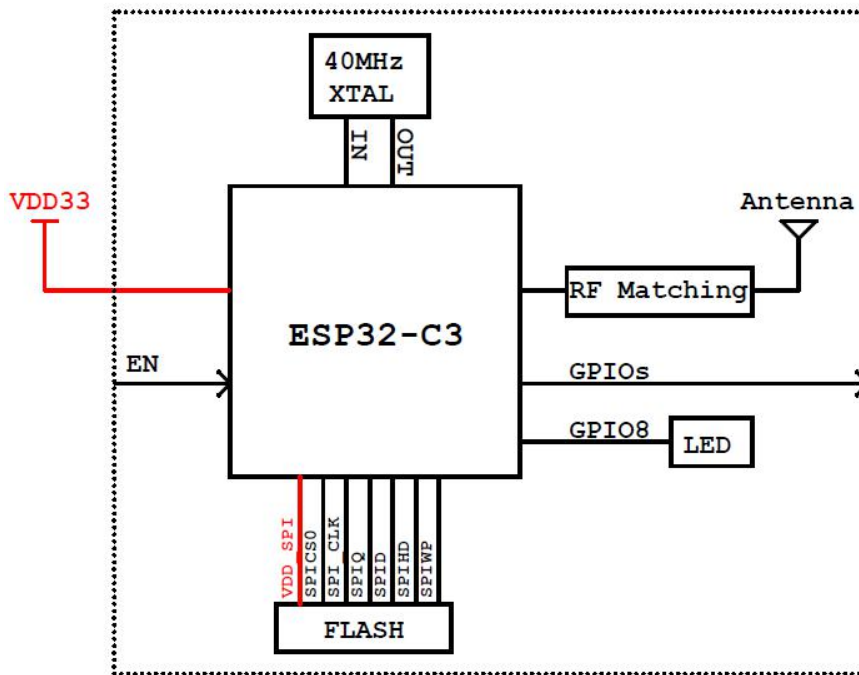

3.2 Pin Descriptions

Figure 2 Pin Layout

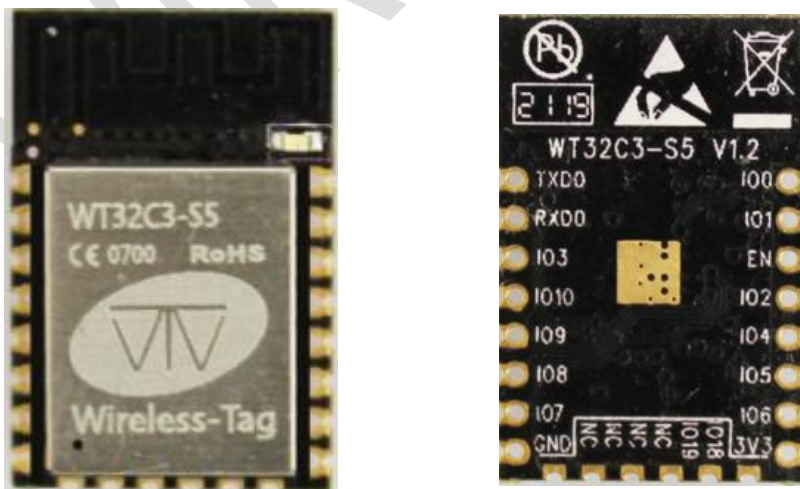

Table 1 Pin Definitions and Descriptions

Pin	Name	Description
1	IO0	GPIO0, ADC1_CH0, XTAL_32K_P (32.768 kHz crystal input)
2	IO1	GPIO1, ADC1_CH1, XTAL_32K_N (32.768 kHz crystal output)
3	EN	Chip Enable pin: High level: on, enables the chip. Low level: off, low current. Note: Do not leave the EN pin floating.
4	IO2	GPIO2, ADC1_CH2, FSPIQ
5	IO4	GPIO4, MTMS, ADC1_CH4, FSPIHD
6	IO5	GPIO5, MTDI, ADC2_CH0, FSPIWP
7	IO6	GPIO6, MTCK, FSPICLK
8	VCC	3.3V power supply; The output current delivered by the external power supply is recommended to be above 500mA.
9	IO18	GPIO18, USB_D
10	IO19	GPIO19, USB_D+
11-14	NC	NC
15	GND	GND
16	IO7	GPIO7, MTDO, FSPID
17	IO8	GPIO8
18	IO9	GPIO9
19	IO10	GPIO10, FSPICS0
20	IO3	GPIO3, ADC1_CH3
21	RXD0	U0RXD, GPIO20
22	TXD0	U0TXD, GPIO21

3.3 Strapping Pins

ESP32-C3 series has three strapping pins.

- GPIO2
- GPIO8
- GPIO9

Software can read the strapping values of these pins in “GPIO_STRAPPING” register.

During the chip’s system reset(power-on reset, RTC watchdog reset, brownout reset, analog super

watchdog reset, crystal clock glitch detection reset), the latches of the strapping pins sample the voltage level as strapping bits of “0” or “1”, and hold these bits until the chip is powered down or shut down.

By default, GPIO9 is connected to the internal pull-up resistor. If GPIO9 is not connected or connected to an external high-impedance circuit, the latched bit value will be “1”.

To change the strapping bit values, you can apply the external pull-down/pull-up resistances, or use the host MCU’s GPIOs to control the voltage level of these pins when powering on ESP32-C3 family.

After reset, the strapping pins work as normal-function pins.

Refer to Table 2 for a detailed boot-mode configuration of the strapping pins.

Note:

Some pins have been internally pulled up, please refer to the schematic diagram.

Table 2 Strapping Pins

Booting Mode ¹			
Pin	Default	SPI Boot	Download Boot
GPIO2	N/A	1	1
GPIO8	N/A	Don't care	1
GPIO9	Internal pull-up	1	0
Enabling/Disabling ROM Code Print During Booting			
Pin	Default	Functionality	
GPIO8	N/A	When the value of eFuse field UART_PRINT_CONTROL is 0, print is enabled and not controlled by GPIO8. 1, if GPIO8 is 0, print is enabled; if GPIO8 is 1, it is disabled. 2, if GPIO8 is 0, print is disabled; if GPIO8 is 1, it is enabled. 3, print is disabled and not controlled by GPIO8.	
Parameter Descriptions of Setup and Hold Times for the Strapping Pin			
Parameter	Description		Min
t0	Setup time before CHIP_EN goes from low to high		0ms
t1	Hold time after CHIP_EN goes high		3ms

Figure 3 shows the setup and hold times for the strapping pin before and after the CHIP_EN signal goes high.

Figure 3 Setup and Hold Times for the Strapping Pin

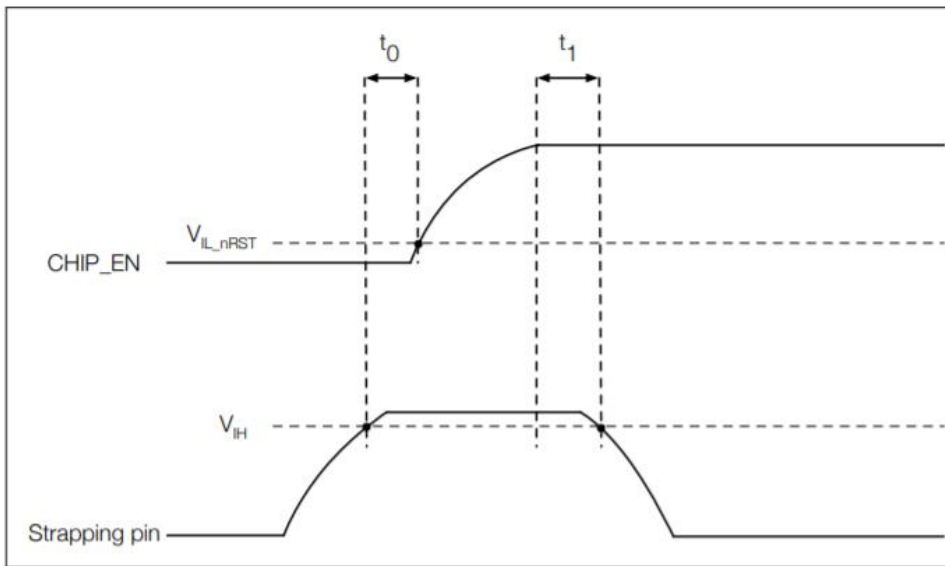

Note:

1. The strapping combination of GPIO8 = 0 and GPIO9 = 0 is invalid.

4 Electrical Characteristics

4.1 Absolute Maximum Ratings

Stresses above those listed in Absolute Maximum Ratings may cause permanent damage to the device. These are stress ratings only and functional operation of the device at these or any other conditions beyond those indicated under Recommended Operating Conditions is not implied. Exposure to absolute-maximum-rated conditions for extended periods may affect device reliability.

4.2 Recommended Operating Conditions

Table 3 Operating Conditions

Symbol	Parameter		Min	Typ	Max	Unit
VDD	Power supply voltage		3.0	3.3	3.6	V
I _{VDD}	Current delivered by external power supply		0.5	-	-	A
T _A	Ambient temperature	85°C version	-40	-	85	°C
		105°C version			105	
Humidity	Humidity condition		-	-	85	%RH

4.3 Current Consumption

Table 4 Current Consumption Depending on RF Modes

Work mode	Description		Peak (mA)
Active(RF working)	TX	802.11b, 1 Mbps, @18dBm	367
		802.11g, 54 Mbps, @15.4dBm	284
		802.11n, HT20, MCS 7, @15 dBm	276
		802.11n, HT40, MCS 7, @14 dBm	252
	RX	802.11b/g/n, HT20	84
		802.11n, HT40	87

Note:

Ambient temperature, 3.3V power supply, TX continues mode, DC power accuracy: 100 μA.

Table 5 Current Consumption Depending on Work Modes

Work mode	Description		Typical value
Modem-sleep	The CPU is powered on	160MHz	23.7mA
		80MHz	20.6mA



Work mode	Description	Typical value
Light-sleep		0.3mA
Deep-sleep		6.5uA
Power off	EN is set to low level	0

WIRELESS-TAG

5 Application Note

5.1 Module Dimensions

Figure 4 Module Dimensions

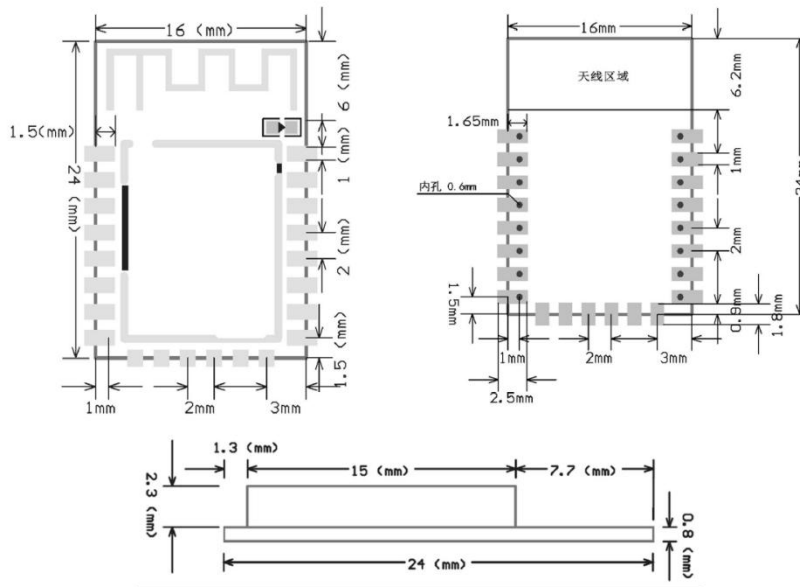

5.2 Reflow Profile

Figure 5 Reflow profile

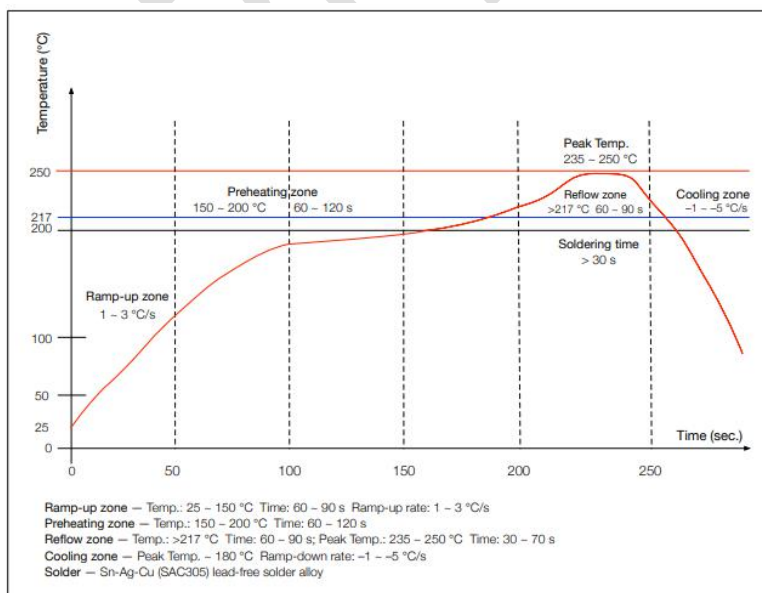

5.3 Module Schematics

Figure 6 Module Schematics

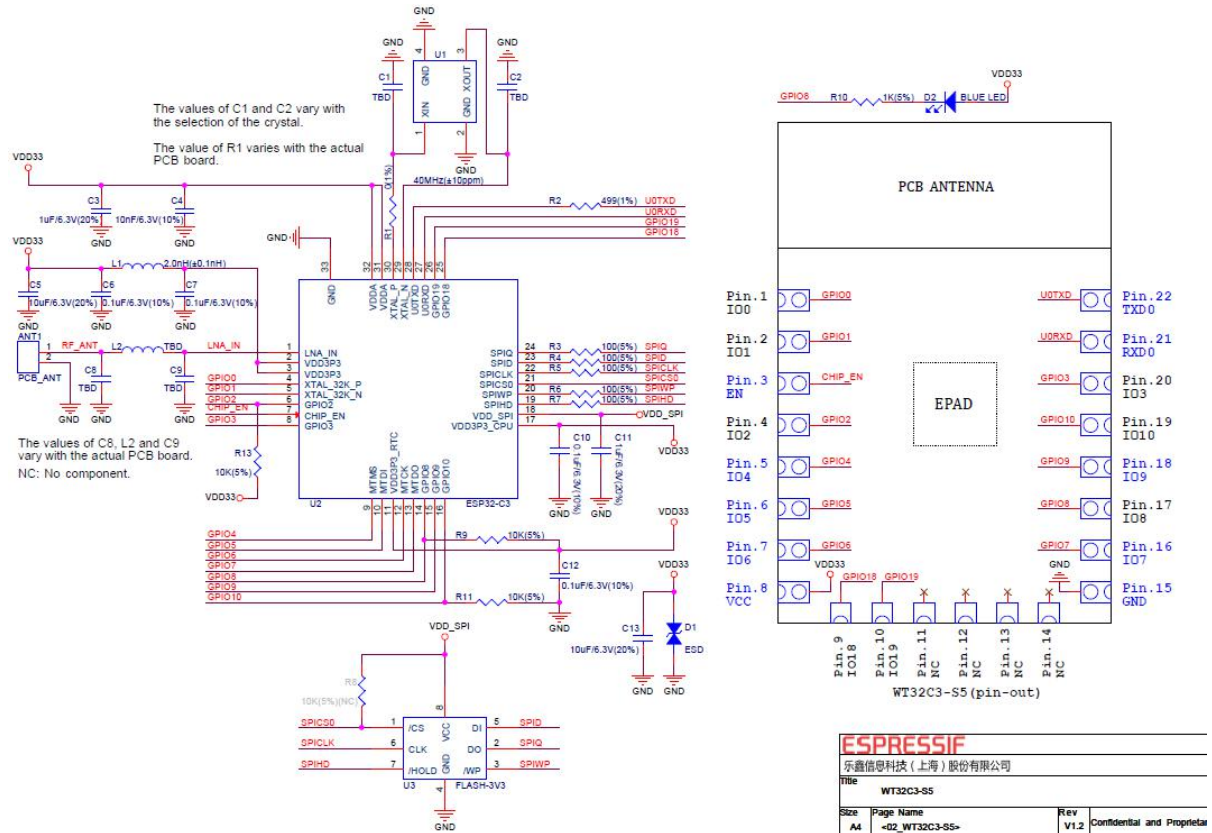

5.4 Peripheral Schematic

This is the typical application circuit of the module connected with peripheral components (for example, power supply, antenna, reset button, JTAG interface, and UART interface).

Figure 7 Application Circuit

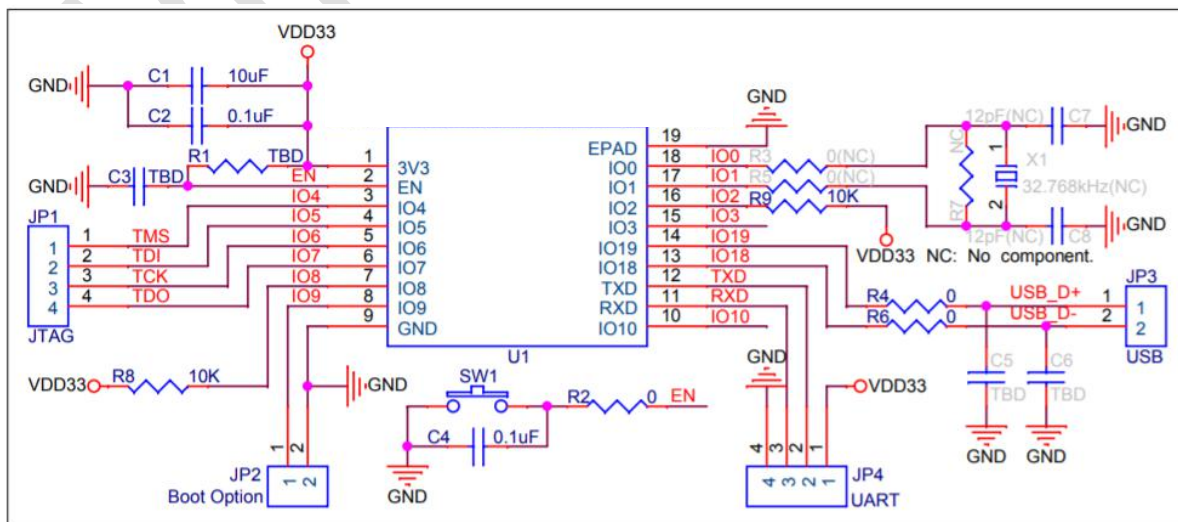

- Soldering the EPAD to the ground of the base board is not a must, though doing so can get optimized thermal performance. If you do want to solder it, please ensure that you apply the correct amount of soldering paste.
- To ensure the power supply to the ESP32-C3 family chip is stable during power-up, it is advised to add an RC delay circuit at the EN pin. The recommended setting for the RC delay circuit is usually $R = 10\text{ k}\Omega$ and $C = 1\text{ }\mu\text{F}$. However, specific parameters should be adjusted based on the power-up timing of the module and the power-up and reset sequence timing of the chip.

6 Product Trial

- Sales email: sales@wireless-tag.com
- Technical support email: technical@wireless-tag.com

WIRELESS-TAG