

WT8266-S2 WiFi Module

Extreme / Open / Small / Easy

Specification

Version 2.5

2018/9/10

Disclaimer and Copyright Notice

Information in this document, including URL references, is subject to change without notice.

THIS DOCUMENT IS PROVIDED AS IS WITH NO WARRANTIES WHATSOEVER, INCLUDING ANY WARRANTY OF MERCHANTABILITY, NON-INFRINGEMENT, FITNESS FOR ANY PARTICULAR PURPOSE, OR ANY WARRANTY OTHERWISE ARISING OUT OF ANY PROPOSAL, SPECIFICATION OR SAMPLE. All liability, including liability for infringement of any proprietary rights, relating to use of information in this document is disclaimed. No licenses express or implied, by estoppel or otherwise, to any intellectual property rights are granted herein.

The WiFi Alliance Member Logo is a trademark of the WiFi Alliance.

All trade names, trademarks and registered trademarks mentioned in this document are property of their respective owners, and are hereby acknowledged.

Note

As the product upgrade or other reasons, this manual may change. Shenzhen Wireless-Tag Technology Co., Ltd has right to modify the contents of this manual without any notice or warning. This manual is only as a guide, Wireless-Tag Technology Co., Ltd Spare no effort to provide accurate information in this manual, but the Wireless-Tag can't guarantee manual there is no problem, all statements in this manual, information and suggestions do not constitute any guarantee of express or implication.

CE marking :

Use the WT8266 in the environment with the temperature between -40°C and 85°C . For the following equipment: WT8266RED (CE 0700) is in compliance with the essential requirements and other relevant provisions of Directive (RED) 2014/53/EU.

Hereby, WIRELESS-TAG TECHNOLOGY CO., LIMITED declares that this WiFi module is in compliance with essential requirements and other relevant provisions of Directive (RED) 2014/53/EU, A copy of the declaration of conformity can be found at www.wireless-tag.com.

Amendment record

Version	Changed by	Time	Reason	Details
V1.0	Lemme	2015.08.13	Original	
V2.0	Lemme	2015.10.12	Update	Flash size Available RAM size Power consumption on deep sleep mode Operating Temperature Model size on top view Schematic of WT8266-S2 FCC/CE/RoHs certification document Tech support email
V2.1	Lemme	2015.10.18	Update	Product picture Environment temperature
V2.2	Lemme	2015.12.29	Update	CE Caution
V2.3	Lemme	2016.1.21	Update	CE marking update
V2.4	Lemme	2016.1.22	Update	Certification update
V2.5	Wangleyu	2018.9.10	Update	Schematic of WT8266-S2 Layout of WT8266-S2 Size description CE marking update RED CE Certification update RoHs certification update

Contents

1. Overview.....	- 5 -
2. Main Features.....	- 5 -
3. Hardware Specifications.....	- 6 -
3.1 System Diagram.....	- 6 -
3.2 Pin Description	- 6 -
3.3 Electrical Characteristic.....	- 9 -
3.3.1 Maximum Ratings.....	- 9 -
3.3.2 Recommended Operating Environment	- 9 -
3.3.3 Digital Port Characteristics	- 9 -
3.4 Power Consumption.....	- 9 -
3.4.1 Operating Power Consumption.....	- 9 -
3.4.2 Standby Power Consumption.....	- 10 -
3.5 RF Characteristics	- 10 -
3.5.1 RF Configuration and General Specifications of Wireless LAN.....	- 10 -
3.5.2 RF Tx Characteristics.....	- 11 -
3.5.3 RF Rx Characteristics	- 11 -
4. Mechanical Dimensions.....	- 11 -
4.1 Module Size	- 11 -
4.2 Schematics.....	- 14 -
5. Certification	- 15 -
6. Product Trial	- 18 -

1. Overview

WT8266-S2 Wi-Fi module is a low consumption, high performance Wi-Fi network control module designed by Wireless-Tag. It can meet the IoT application requirements in smart power grids, building automation, security and protection, smart home, remote health care etc.

The module's core processor ESP8266 integrates an enhanced version of Tensilica's L106 Diamond series 32-bit processor with smaller package size and 16 bit compact mode, main frequency support 80 MHz and 160 MHz, support RTOS, integrated Wi-Fi MAC / BB / RF / PA / LNA, on-board PCB antenna.

The module supports standard IEEE802.11 b / g / n protocol, a complete TCP / IP protocol stack. It can be used to host the application or to offload Wi-Fi networking functions from another application processor.

2. Main Features

- Operating Voltage: 3.3V
- Operating Temperature: -40-85°C
- CPU Tensilica L106
 - RAM 50KB (Available)
 - Flash 16Mbit/32Mbit (16Mbit default)
- System
 - 802.11 b/g/n
 - Integrated Tensilica L106 ultra-low power 32-bit micro MCU, with 16-bit RSIC. The CPU clock speed is 80MHz. It can also reach a maximum value of 160MHz.
 - WIFI 2.4 GHz, support WPA/WPA2
 - Ultra-Small 18.6mm*15.0mm
 - Integrated 10 bit high precision ADC
 - Integrated TCP/IP Stack
 - Integrated TR switch, balun, LNA, Power amplifier and matching network
 - Integrated PLL, Regulator and power source management components, +20 dBm output power in 802.11b mode
 - Supports antenna diversity
 - Deep sleep current < 20uA, Power down leakage current < 5uA
 - Rich interface on processor: SDIO 2.0, (H) SPI, UART, I2C, I2S, IRDA, PWM, GPIO
 - STBC, 1x1 MIMO, 2x1 MIMO, A-MPDU & A-MSDU aggregation & 0.4s guard interval
 - Wake up, build the connection and transmit packets in < 2ms
 - Standby power consumption < 1.0mW (DTIM3)
 - Support AT remote upgrades and cloud OTA upgrade
 - Support STA/AP/STA+AP operation modes

- FCC/CE/RoHs

3. Hardware Specifications

3.1 System Diagram

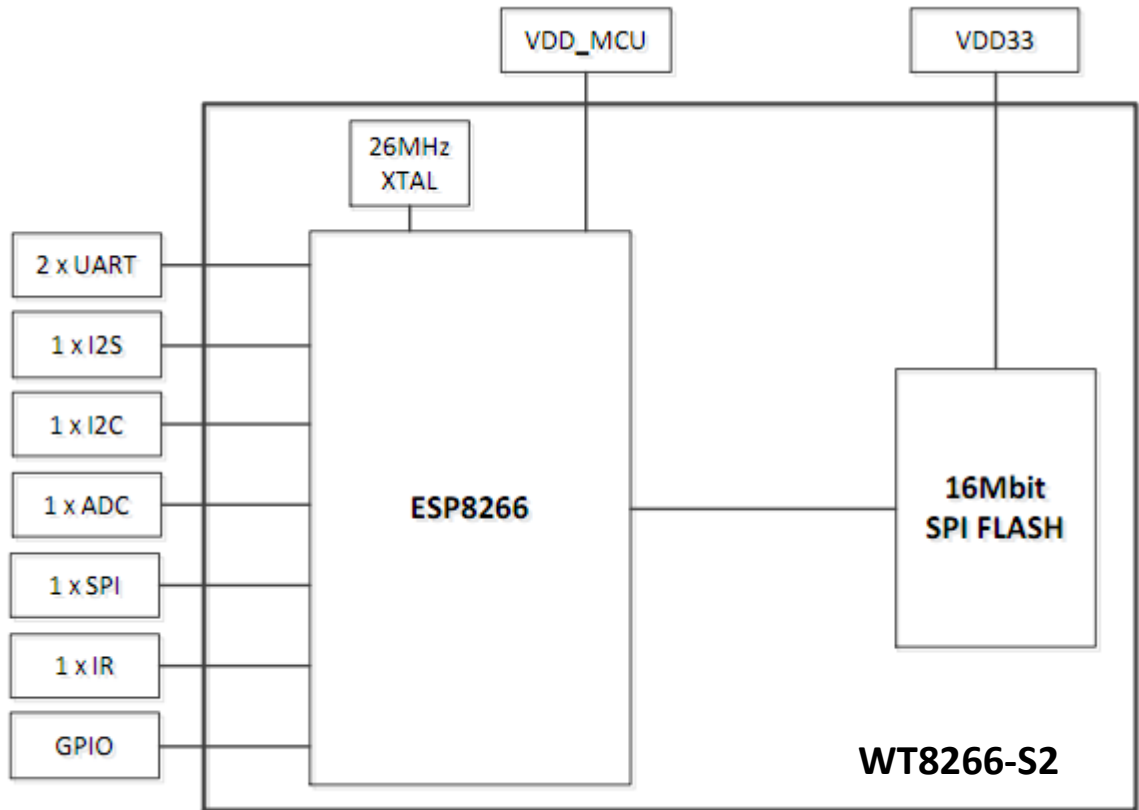

Figure-1 System Diagram

3.2 Pin Description



Figure-2 Physical Map (Top View)

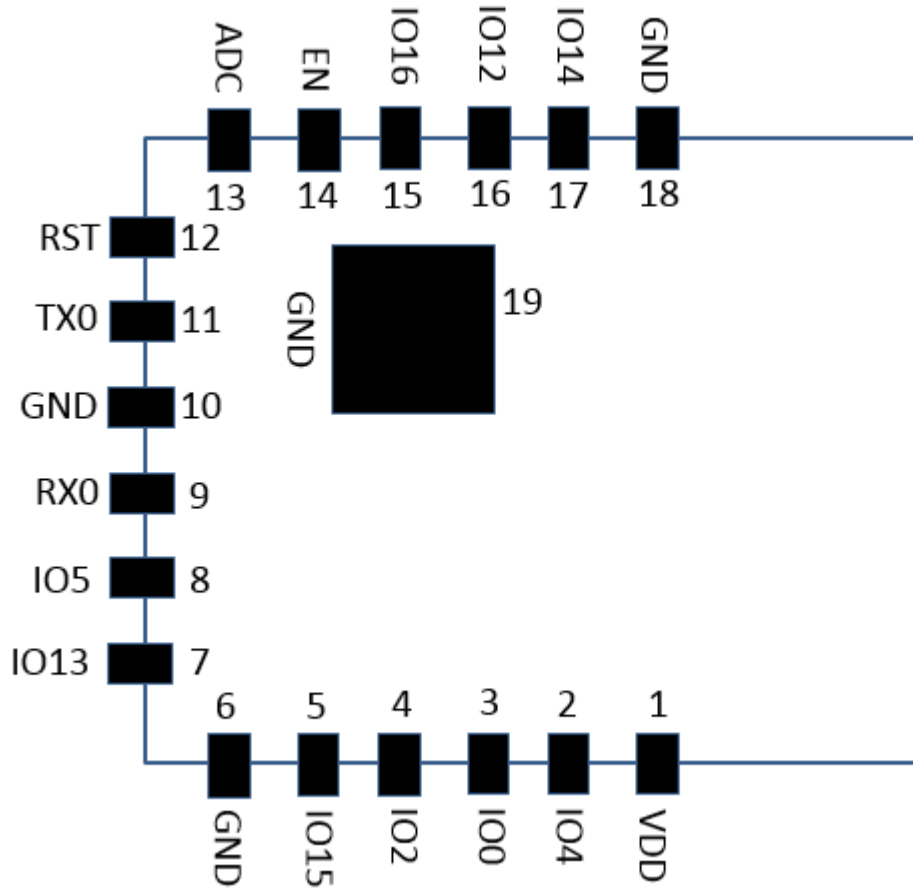

Figure-3 WT8266-S2 Pinout (Bottom View)

Table 1 Pin Definition and Description

Pin	Name	Description
1	VDD	3.3V supply (VDD)
2	IO4	GPIO4
3	IO0	GPIO0
4	IO2	GPIO2;UART1_TXD
5	IO15	GPIO15;MIDO; HSPICS;UART0_RTS
6	GND	GND
7	IO13	GPIO13; HSPI_MOSI;UART0_CTS
8	IO5	GPIO5
9	RX0	UART0_RXD;GPIO3
10	GND	GND
11	TX0	UART0_TXD;GPIO1
12	RST	Reset Module
13	ADC	Detecting chip VDD3P3 supply voltage or ADC pin input voltage (not available at the same time)

14	EN	Chip Enable. High: On, chip works properly; Low: Off, small current
15	IO16	GPIO16; Deep sleep wakeup, by connecting to RST pin
16	IO12	GPIO12;HSPI_MISO
17	IO14	GPIO14;HSPI_CLK
18	GND	GND
19	GND	GND PAD

Note:

Table-2 Pin Mode

Mode	IO15	IO0	IO2
UARTDownload Mode	Low	Low	High
Flash Boot Mode	Low	High	High

Table-3 Interface Description

Name	Pin	Function Description
HSPI Interface	IO12(MISO),IO13(MOSI),IO14(CLK),IO15(CS)	Can connect external SPI Flash, display and MCU etc.
PWM Interface	IO12(R),IO15(G),IO13(B)	The official demo provides4-channel PWM (user can expand to 8-channel), can be used to control lights, buzzers, relays and motors, etc.
IR Interface	IO14(IR_T), IO5(IR_R)	The functionality of Infrared remote control interface can be implemented via software programming. NEC coding, modulation, and demodulation are used by this interface. The frequency of modulated carrier signal is 38KHz.
ADC Interface	ADC	ESP8266EX integratesa 10-bit precision SARADC. ADC_IN interface is used to test the power supply voltage of VDD3P3(Pin 3 and Pin 4), as well as the input voltage of TOUT (Pin 6). It can be used in sensors application.
I2C Interface	IO14(SCL), IO2(SDA)	Can connect to external sensor and display, etc.
UART Interface	UART0: TX0(U0TXD),RX0(U0RXD), IO15(RTS),IO13(CTS) UART1: IO2(TX0)	Devices with UART interfaces can be connected Download: U0TXD+U0RXD or GPIO2+U0RXD Communication: (UART0):U0TXD,U0RXD,MTDO(U0RTS),MTCK(U0CTS) Debug: UART1_TXD(GPIO2)Can be used to print debugging information
		By default, UART0 will output some printed information when the device is powered on and is booting up. If this issue exerts influence on some specific applications, users can exchange the inner pins of UART when initializing, that is to say, exchange U0TXD, U0RXD with U0RTS, U0CTS.

I2S Interface	I2S input: IO12 (I2SI_DATA); IO13 (I2SI_BCK); IO14 (I2SI_WS);	Mainly used for audio capturing, processing and transmission.
	I2S output: IO15 (I2SO_BCK); IO3 (I2SO_DATA); IO2 (I2SO_WS);	

3.3 Electrical Characteristic

3.3.1 Maximum Ratings

Table- 4. Maximum Ratings

Ratings	Condition	Value	Unit
Storage Temperature	/	-45 to 125	°C
Maximum Soldering Temperature	/	260	°C
Supply Voltage	IPC/JEDEC J-STD-020	+3.0 to +3.6	V

3.3.2 Recommended Operating Environment

Table -5 Recommended Operating Environment

Working Environment	Name	Min Value	Typical Values	Max Value	Unit
Operating Temperature	/	-40	20	85	°C
Supply Voltage	VDD	3.0	3.3	3.6	V

3.3.3 Digital Port Characteristics

Table -6 Digital Port Characteristics

Port	Typical Values	Min Value	Max Value	Unit
Input low logic level	VIL	-0.3	0.25VDD	V
Input high logic level	VIH	0.75vdd	VDD+0.3	V
Output low logic level	VOL	N	0.1VDD	V
Output high logic level	VOL	0.8VDD	N	V

3.4 Power Consumption

3.4.1 Operating Power Consumption

Table -7 Operating Power Consumption

Mode	Standard	Speed Rate	Typical Value	Unit
Tx	11b	1	215	mA

		11	197	
	11g	6	197	
		54	145	
	11n	MCS7	120	
Rx	All rates		56	mA

Note: RX mode data packet length is 1024 bytes;

3.4.2 Standby Power Consumption

The following current consumption is based on 3.3V supply and 25°C ambient with internal regulators. Values are measured at antenna port without SAW filter. All the transmission measurements values are based on 90% duty cycle, continuous transmission mode.

Table -8 Standby Power Consumption

Mode	Status	Typical Value				
Standby	Modem Sleep	15mA				
	Light Sleep	0.9mA				
	Deep Sleep	20uA				
	Off	0.5uA				
Power Save Mode (2.4G) (Low Power Listen disabled) ¹	DTIM period	Current Cons. (mA)	T1 (ms)	T2 (ms)	Tbeacon (ms)	T3 (ms)
	DTIM 1	1.2	2.01	0.36	0.99	0.39
	DTIM 3	0.9	1.99	0.32	1.06	0.41

①: Modem-Sleep requires the CPU to be working, as in PWM or I2S applications. According to 802.11 standards (like U-APSD), it saves power to shut down the Wi-Fi Modem circuit while maintaining a Wi-Fi connection with no data transmission. E.g. in DTIM3, to maintain a sleep 300ms-wake 3ms cycle to receive AP's Beacon packages, the current is about 15mA.

②: During Light-Sleep, the CPU may be suspended in applications like Wi-Fi switch. Without data transmission, the Wi-Fi Modem circuit can be turned off and CPU suspended to save power according to the 802.11 standard (U-APSD). E.g. in DTIM3, to maintain a sleep 300ms-wake 3ms cycle to receive AP's Beacon packages, the current is about 0.9mA.

③: Deep-Sleep does not require Wi-Fi connection to be maintained. For application with long time lags between data transmission, e.g. a temperature sensor that checks the temperature every 100s, sleep 300s and waking up to connect to the AP (taking about 0.3~1s), the overall average current is less than 1mA.

3.5 RF Characteristics

3.5.1 RF Configuration and General Specifications of Wireless LAN

Table-9 RF Configuration and General Specifications of Wireless LAN

Items	Specifications	Unit
Country/Domain Code	Reserved	—

Center Frequency	11b	2.412-2.472	GHz
	11g	2.412-2.472	GHz
	11n HT20	2.412-2.472	GHz
Rate	11b	1, 2, 5.5, 11	Mbps
	11g	6, 9, 12, 18, 24, 36, 48, 54	Mbps
	11n 1stream	MCS0, 1, 2, 3, 4, 5, 6, 7	Mbps
Modulation type	11b	DSSS	—
	11g/n	OFDM	—

3.5.2 RF Tx Characteristics

Table-10 Emission Characteristics

Mark	Parameters	Condition	Min Value	Typical Value	Max Value	Unit
Ftx	Input Frequency	—	2.412	—	2.484	GHz
Pout	Output Power					
	11b	1Mbps	—	19.5	—	dBm
		11Mbps	—	18.5	—	dBm
		54Mbps	—	16	—	dBm
		MCS7	—	14	—	dBm

3.5.3RF Rx Characteristics

Table-11RF Receiving Characteristics

Mark	Parameters	Condition	Min Value	Typical Value	Max Value	Unit
Frxf	Input Frequency	—	2.412	—	2.484	GHz
Srf	Sensitivity					
	DSSS	1 Mbps	—	-98	—	dBm
		11 Mbps	—	-91	—	dBm
	OFDM	6 Mbps	—	-93	—	dBm
		54 Mbps	—	-75	—	dBm
	HT20	MCS7	—	-71	—	dBm

4. Mechanical Dimensions
4.1Module Size

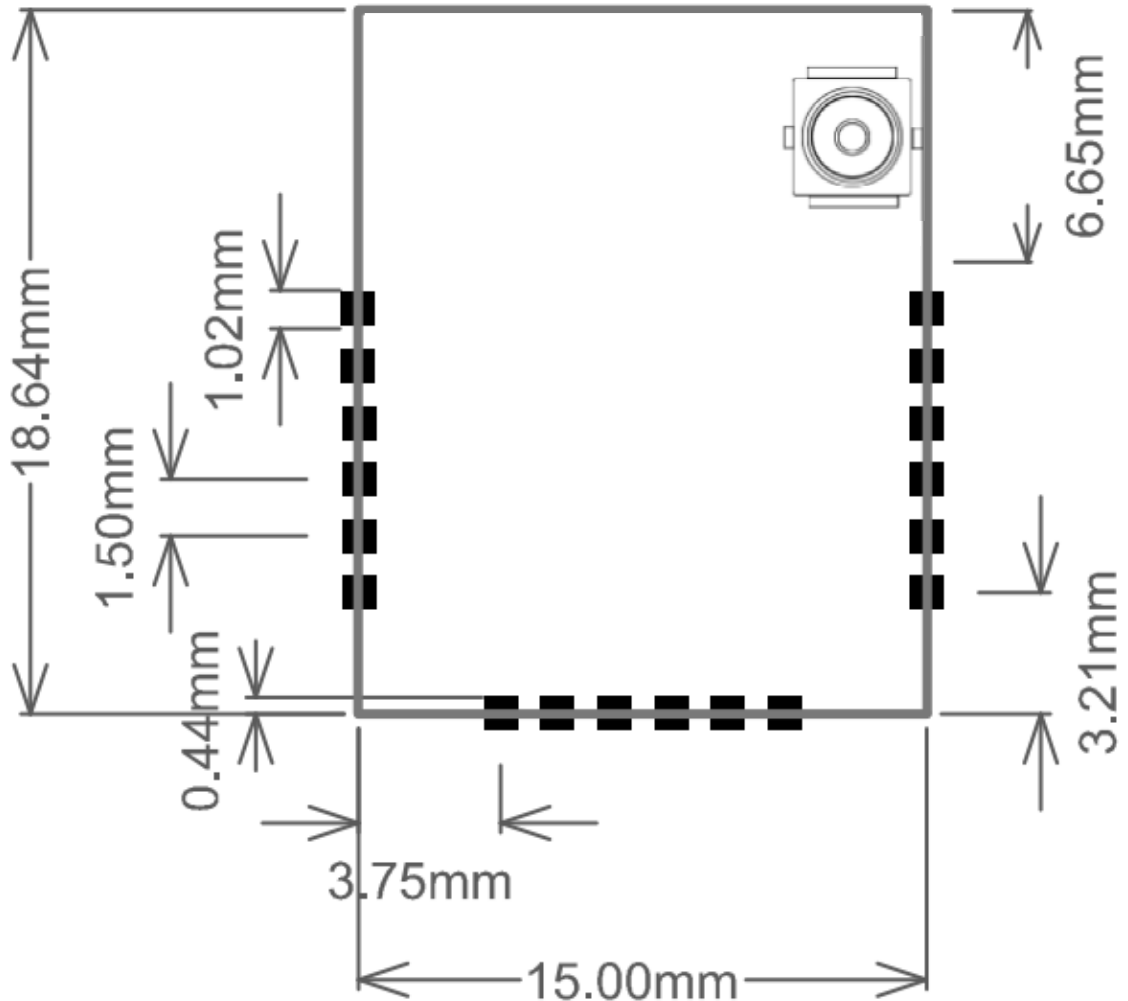

Figure -4 Module Size (Front View)

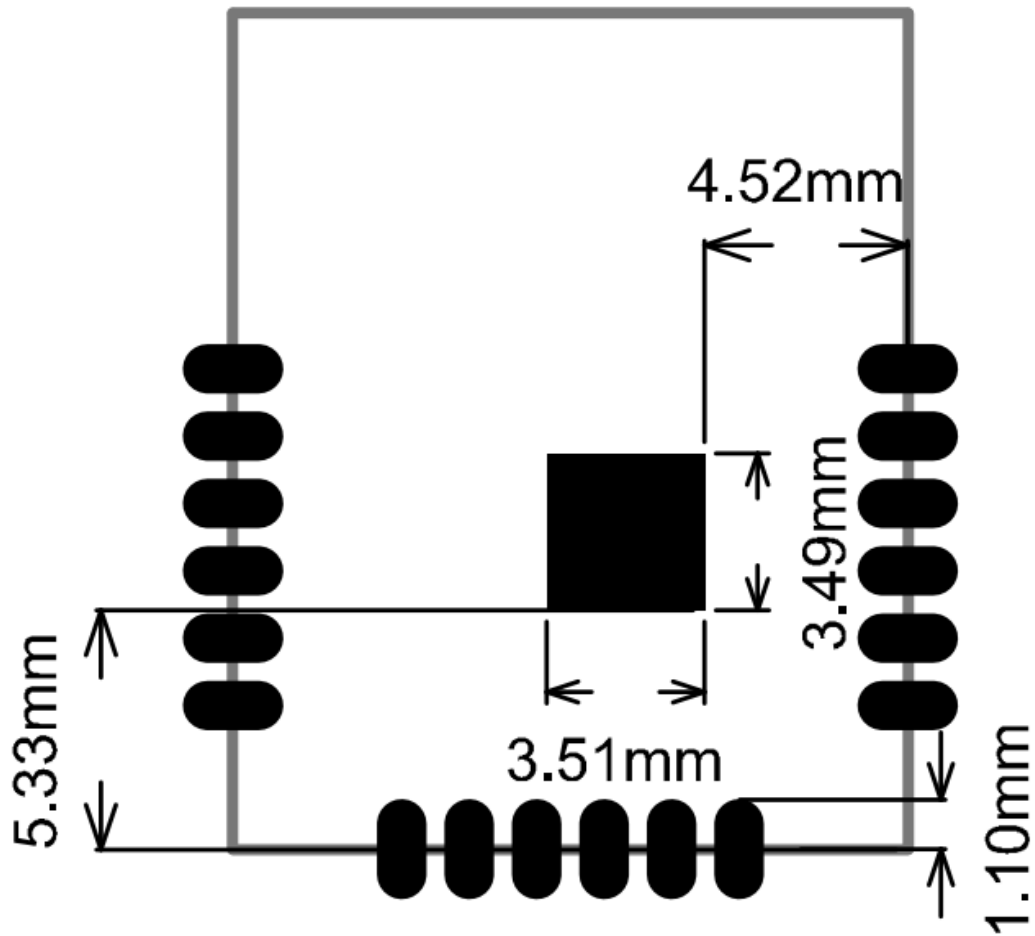

Figure -4-1 Module Size (reverse projection view)

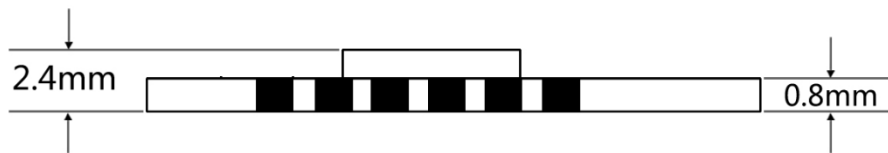

Figure -5 Module Size (Side View)



Figure -6 Module Size - shieldingcase (Side View)

4.2 Schematics

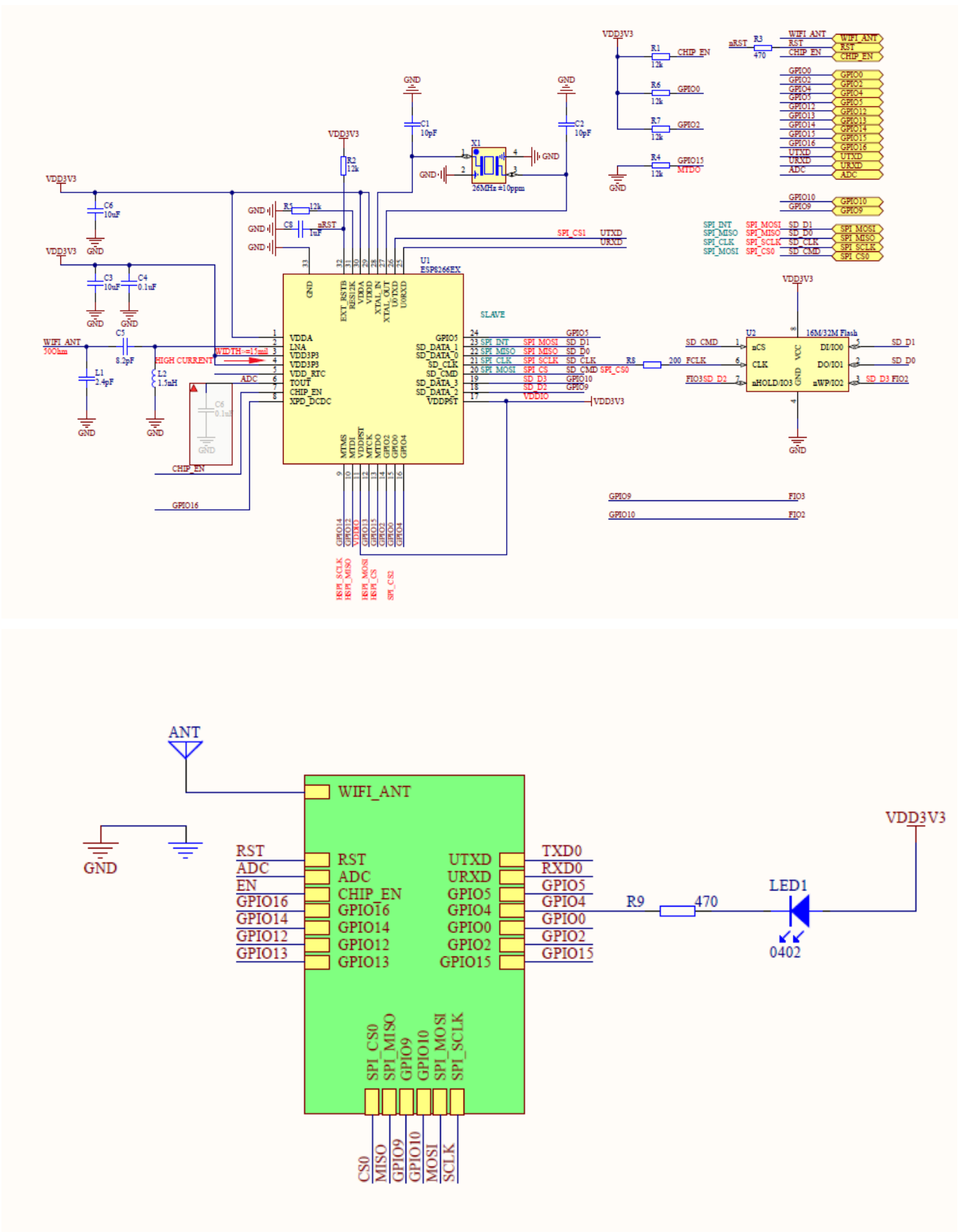

Figure -7 WT8266-S2 Schematics

5. Certification

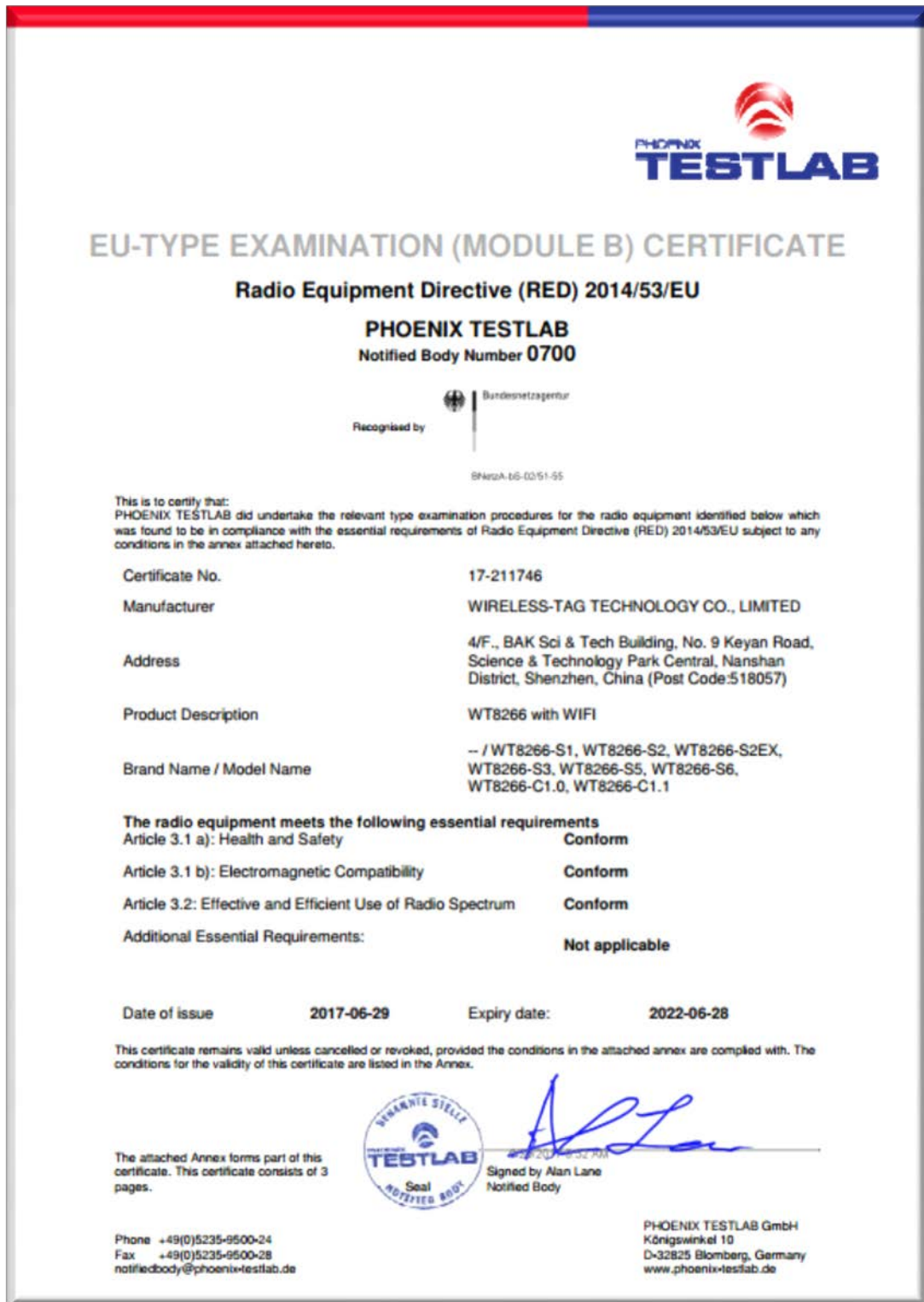

Figure -8RED (CE 0700) Certification

Teleconformity
 URL: www.teleconformity.com
 Trade Register: 61843547

Confirmation of Certification
 Teleconformity No: 2015FCC209R0

TCB

**GRANT OF EQUIPMENT
 AUTHORIZATION**
 Certification
 Issued Under the Authority of the
 Federal Communications Commission
 By

TCB

MICOM Labs
 440 Boulder Court Suite 200
 Pleasanton CA 94566

Date of Grant: 09/01/2015
 Application Dated: 09/01/2015

WIRELESS-TAG TECHNOLOGY CO., LIMITED
 4/F.,BAK Sci & Tech Building,No. 9 Keyan Road,
 Science & Technology Park Central
 Nanshan District,Shen Zhen,
 China

Attention: Ming Li , Manager

NOT TRANSFERABLE

EQUIPMENT AUTHORIZATION is hereby issued to the named GRANTEE, and is VALID ONLY
 for the equipment identified hereon for use under the Commission's Rules and Regulations listed
 below:

FCC IDENTIFIER: 2AF0SWT8266
 Name of Grantee: WIRELESS-TAG TECHNOLOGY CO., LIMITED
 Equipment Class: Digital Transmission System
 Notes: WT8266 Module
 Modulare Type: Single Modular

Grant Notes	FCC Rule Parts	Frequency Range (MHZ)	Output Watts	Frequency Tolerance	Emission Designator
20	15C	2412.0 - 2462.0	0.0766		

Modular Approval. Power Output listed is conducted. Approval is limited to OEM installation only. The antenna(s) used for this transmitter must be installed to provide a separation distance of at least 20 cm from all persons and must not be co-located or operating in conjunction with any other antenna or transmitter. OEM Integrators must be provided with antenna installation instructions. OEM integrators and end-users must be provided with transmitter operation conditions for satisfying RF exposure compliance. This Grant is valid only when the device is sold to OEM integrators and the OEM integrators are instructed to ensure that the end user has no manual instructions to remove or install the device. Use in RFI category Portable applications will require SAR testing

20: All electrical and mechanical devices employed for spurious radiation suppression, including any modifications made during certification testing, must be incorporated in each unit marketed.

Confirmation Date: 2015-09-01

Agency attestation: TELECONFORMITY
 Function: Mr. M. Koop
 Manager



Figure -9FCC Certification



Figure -10 RoHSCertification

6. Product Trial

- Forum: bbs.wireless-tag.com