

WT-01F WiFi Module

Extreme / Open / Small / Easy

Specification

Version 1.0

2019/01/13

Disclaimer and Copyright Notice

Information in this document, including URL references, is subject to change without notice.

THIS DOCUMENT IS PROVIDED AS IS WITH NO WARRANTIES WHATSOEVER, INCLUDING ANY WARRANTY OF MERCHANTABILITY, NON-INFRINGEMENT, FITNESS FOR ANY PARTICULAR PURPOSE, OR ANY WARRANTY OTHERWISE ARISING OUT OF ANY PROPOSAL, SPECIFICATION OR SAMPLE. All liability, including liability for infringement of any proprietary rights, relating to use of information in this document is disclaimed. No licenses express or implied, by estoppel or otherwise, to any intellectual property rights are granted herein.

The WiFi Alliance Member Logo is a trademark of the WiFi Alliance.

All trade names, trademarks and registered trademarks mentioned in this document are property of their respective owners, and are hereby acknowledged.

Note

As the product upgrade or other reasons, this manual may change. Shenzhen Wireless-Tag Technology Co., Ltd has right to modify the contents of this manual without any notice or warning. This manual is only as a guide, Wireless-Tag Technology Co., Ltd Spare no effort to provide accurate information in this manual, but the Wireless-Tag can't guarantee manual there is no problem, all statements in this manual, information and suggestions do not constitute any guarantee of express or implication.

CE marking :

Use the WT-01F in the environment with the temperature between -40°C and 85°C. For the following equipment: WT-01FRED (CE 0700) is in compliance with the essential requirements and other relevant provisions of Directive (RED) 2014/53/EU.

Hereby, WIRELESS-TAG TECHNOLOGY CO., LIMITED declares that this WiFi module is in compliance with essential requirements and other relevant provisions of Directive (RED) 2014/53/EU, A copy of the declaration of conformity can be found at www.wireless-tag.com.

Amendment record

Version	Changed by	Time	Reason	Details
V1.0	Louie	2019.01.13	Original	

Contents

- 1. Overview..... - 5 -
- 2. Main Features..... - 5 -
- 3. Hardware Specifications..... - 6 -
 - 3.1 System Diagram..... - 6 -
 - 3.2 Pin Description - 6 -
 - 3.3 Electrical Characteristic..... - 8 -
 - 3.3.1 Maximum Ratings..... - 8 -
 - 3.3.2 Recommended Operating Environment - 8 -
 - 3.3.3 Digital Port Characteristics - 8 -
 - 3.4 Power Consumption..... - 9 -
 - 3.4.1 Operating Power Consumption..... - 9 -
 - 3.4.2 Standby Power Consumption - 9 -
 - 3.5 RF Characteristics - 10 -
 - 3.5.1 RF Configuration and General Specifications of Wireless LAN..... - 10 -
 - 3.5.2 RF Tx Characteristics..... - 10 -
 - 3.5.3 RF Rx Characteristics - 10 -
- 4. Application Specification - 11 -
 - 4.1 Module Size - 11 -
 - 4.2 Reflow Profile - 12 -
 - 4.3 Schematics..... - 13 -
- 5. Certification - 13 -
- 6. Product Trial - 15 -

1. Overview

WT-01F Wi-Fi module is a low consumption, high performance Wi-Fi network control module designed by Wireless-Tag. It can meet the IoT application requirements in smart power grids, building automation, security and protection, smart home, remote health care etc.

The module's core processor ESP8285 integrates an enhanced version of Tensilica's L106 Diamond series 32-bit processor with smaller package size and 16 bit compact mode, main frequency support 80 MHz and 160 MHz, support RTOS, integrated Wi-Fi MAC / BB / RF / PA / LNA, Spring antenna interface .

The module supports standard IEEE802.11 b / g / n protocol, a complete TCP / IP protocol stack.it can be used to host the application or to offload Wi-Fi networking functions from another application processor.

2. Main Features

- SMD-18 package for easy welding
- Spring Antenna Interface
- Operating Voltage: 3.3V
- Operating Temperature: -20-85°C
- CPU Tensilica L106
 - RAM 50KB (Available)
 - Chip built-in 1 MB flash
- System
 - 802.11 b/g/n
 - Integrated Tensilica L106 ultra-low power 32-bit micro MCU, with 16-bit RSIC. The CPU clock speed is 80MHz. It can also reach a maximum value of 160MHz.
 - WIFI 2.4 GHz, support WEP/WPA-PSK/WPA2-PSK
 - Ultra-Small 11mm*10mm*2.8mm(±0.2mm)
 - Integrated 10 bit high precision ADC
 - Integrated TCP/IP Stack
 - Integrated TR switch, balun, LNA, Power amplifier and matching network
 - Deep sleep current < 20uA, Power down leakage current < 5uA
 - Standby power consumption < 1.0mW (DTIM3)
 - UART baud rate up to 4Mbps
 - Support AT remote upgrades and cloud OTA upgrade
 - Support STA/AP/STA+AP operation modes
 - FCC/CE/RoHS

3. Hardware Specifications

3.1 System Diagram

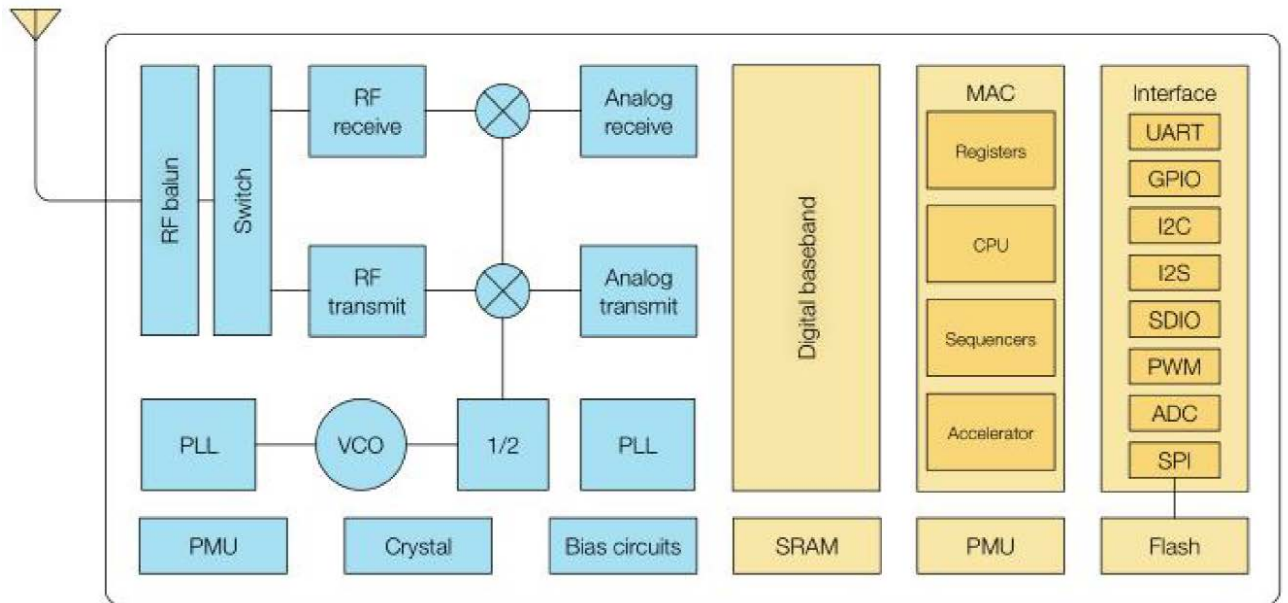

Figure-1 System Diagram

3.2 Pin Description

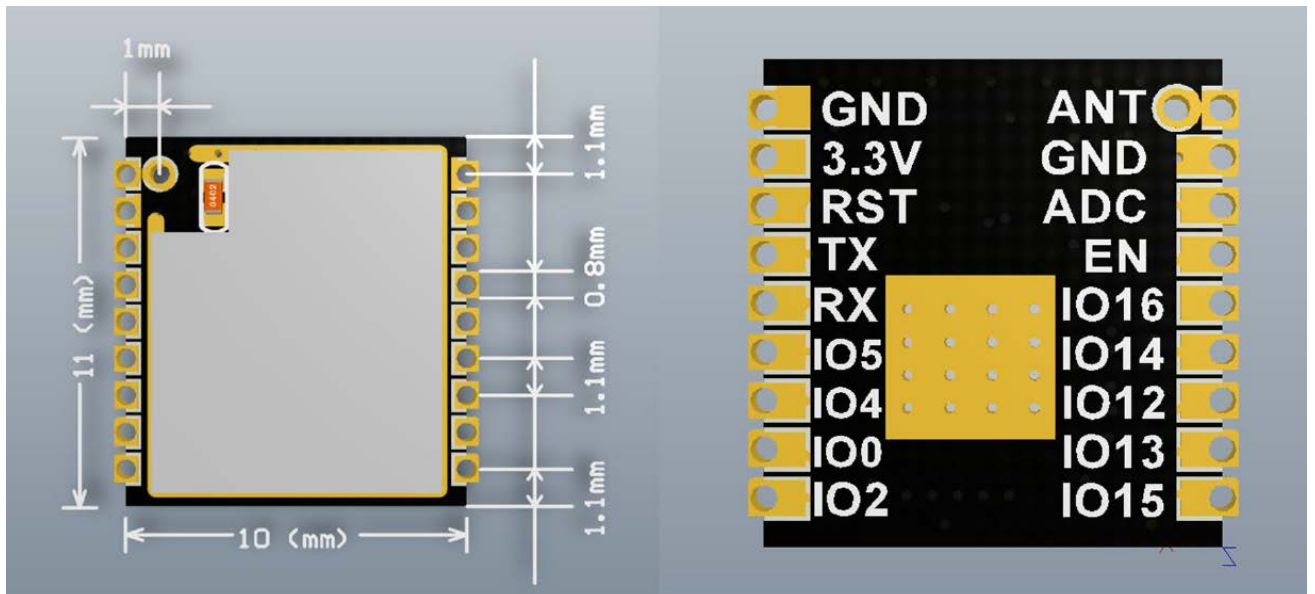

Figure-2 Physical Map

Table 1 Pin Definition and Description

Pin	Name	Description
1	ANT	ANT
2	GND	GND
3	ADC	Detecting chip VDD3P3 supply voltage or ADC pin input voltage (not available at the same time). Input voltage range 0~1V, the value range is 0~1024.
4	EN	Chip Enabled Pin, Active High
5	IO16	Connect with RST pin to wake up Deep Sleep
6	IO14	GPIO14; HSPI_CLK
7	IO12	GPIO12; HSPI_MISO
8	IO13	GPIO13; HSPI_MOSI; UART0_CTS
9	IO15	GPIO15; MTDO; HSPICS; UART0_RTS
10	IO2	GPIO2; UART1_TXD
11	IO0	GPIO0;HSPI_MISO;I2SI_DATA
12	IO4	GPIO4
13	IO5	GPIO5;IR_R
14	RX	UART0_RXD; GPIO3
15	TX	UART0_TXD; GPIO1
16	RST	Reset Pin, Active Low
17	VDD	Module power supply pin, Voltage 3.0V ~ 3.6V
18	GND	GND

Note:
Table-2 Pin Mode

Mode	EN	RST	TXD0	IO15	IO0	IO2
UARTDownl oad Mode	High	High	High	Low	Low	High
Flash Boot Mode	High	High	High	Low	High	High

Table-3 Interface Description

Name	Pin	Function Description
HSPI Interface	IO12(MISO),IO13(MOSI),I O14(CLK),IO15(CS)	Can connect external SPI Flash, display and MCU etc.
PWM Interface	IO12(R),IO15(G),IO13(B)	The official demo provides4-channel PWM (user can expand to 8-channel), can be used to control lights, buzzers, relays and motors, etc.

IR Interface	IO14(IR_T), IO5(IR_R)	The functionality of Infrared remote control interface can be implemented via software programming. NEC coding, modulation, and demodulation are used by this interface. The frequency of modulated carrier signal is 38KHz.
ADC Interface	ADC	ESP8285EX Integrated 10-bit precision SARADC. ADC_IN interface is used to test the power supply voltage of VDD3P3(Pin 3 and Pin 4), as well as the input voltage of TOUT (Pin 6). It can be used in sensors application.
I2C Interface	IO14(SCL), IO2(SDA)	Can connect to external sensor and display, etc.
UART Interface	UART0: TX0(U0TXD),RX0(U0RXD), IO15(RTS),IO13(CTS) UART1: IO2(TX0)	Devices with UART interfaces can be connected Download: U0TXD+U0RXD or GPIO2+U0RXD Communication: (UART0):U0TXD,U0RXD,MTDO(U0RTS),MTCK(U0CTS) Debug: UART1_TXD(GPIO2)Can be used to print debugging information
		By default, UART0 will output some printed information when the device is powered on and is booting up. If this issue exerts influence on some specific applications, users can exchange the inner pins of UART when initializing, that is to say, exchange U0TXD, U0RXD with U0RTS, U0CTS.

3.3Electrical Characteristic

3.3.1Maximum Ratings

Table- 4. Maximum Ratings

Ratings	Condition	Value	Unit
Storage Temperature	/	-40 to 85	°C
Maximum Soldering Temperature	/	260	°C
Supply Voltage	IPC/JEDEC J-STD-020	+2.7 to +3.6	V

3.3.2Recommended Operating Environment

Table -5 Recommended Operating Environment

Working Environment	Name	Min Value	Typical Values	Max Value	Unit
Operating Temperature	/	-20	20	85	°C
Supply Voltage	VDD	2.7	3.3	3.6	V

3.3.3Digital Port Characteristics

Table -6 Digital Port Characteristics

Port	Typical Values	Min Value	Max Value	Unit
Input low logic level	VIL	-0.3	0.25VDD	V
Input high logic level	VIH	0.75vdd	VDD+0.3	V

Output low logic level	VOL	N	0.1VDD	V
Output high logic level	VOL	0.8VDD	N	V

3.4 Power Consumption

3.4.1 Operating Power Consumption

Table -7 Operating Power Consumption

Mode	Standard	Speed Rate	Typical Value	Unit
Tx	11b	11	170	mA
	11g	54	140	
	11n	MCS7	120	
Rx	All rates		56	mA

Note: RX mode data packet length is 1024 bytes;

3.4.2 Standby Power Consumption

The following current consumption is based on 3.3V supply and a voltage stabilizer, in 25°C ambient temperature. Values are measured at antenna port without SAW filter. All the transmission measurements values are based on 90% duty cycle, continuous transmission mode.

Table -8 Standby Power Consumption

Mode	Status	Typical Value				
Standby	Modem Sleep	20mA				
	Light Sleep	2mA				
	Deep Sleep	20uA				
	Off	0.5uA				
Power Save Mode (2.4G) (Low Power Listen disabled) ¹	DTIM period	Current Cons. (mA)	T1 (ms)	T2 (ms)	Tbeacon (ms)	T3 (ms)
	DTIM 1	1.2	2.01	0.36	0.99	0.39
	DTIM 3	0.9	1.99	0.32	1.06	0.41

①: Modem-Sleep requires the CPU to be working, as in PWM or I2S applications. According to 802.11 standards (like U-APSD), it saves power to shut down the Wi-Fi Modem circuit while maintaining a Wi-Fi connection with no data transmission. E.g. in DTIM3, to maintain a sleep 300ms-wake 3ms cycle to receive AP's Beacon packages, the current is about 20mA.

②: During Light-Sleep, the CPU may be suspended in applications like Wi-Fi switch. Without data transmission, the Wi-Fi Modem circuit can be turned off and CPU suspended to save power according to the 802.11 standard (U-APSD). E.g. in DTIM3, to maintain a sleep 300ms-wake 3ms cycle to receive AP's Beacon packages, the current is about 2mA.

③: Deep-Sleep does not require Wi-Fi connection to be maintained. For application with long timelags between data transmission, e.g. a temperature sensor that checks the temperature every 100s, sleep 300s and waking up to connect to the AP (taking about 0.3~1s), the overall average current is less than 1mA.

3.5 RF Characteristics

3.5.1 RF Configuration and General Specifications of Wireless LAN

Table-9 RF Configuration and General Specifications of Wireless LAN

Items	Specifications		Unit
Country/Domain Code	Reserved		—
Center Frequency	11b	2.412-2.472	GHz
	11g	2.412-2.472	GHz
	11n HT20	2.412-2.472	GHz
Rate	11b	1, 2, 5.5, 11	Mbps
	11g	6, 9, 12, 18, 24, 36, 48, 54	Mbps
	11n 1stream	MCS0, 1, 2, 3, 4, 5, 6, 7	Mbps
Modulation type	11b	DSSS	—
	11g/n	OFDM	—

3.5.2 RF Tx Characteristics

Table-10 Emission Characteristics

Mark	Parameters	Condition	Min Value	Typical Value	Max Value	Unit
Ftx	Input Frequency	—	2.412	—	2.484	GHz
Pout	Output Power					
		PA output power in 11b mode	19.5	20.5	21.5	dBm
		PA output power at 72.2 Mbps	15.5	16.5	17.5	dBm

3.5.3 RF Rx Characteristics

Table-11 RF Receiving Characteristics

Mark	Parameters	Condition	Min Value	Typical Value	Max Value	Unit
FrX	Input Frequency	—	2.412	—	2.484	GHz
Srf	Sensitivity					
	DSSS	1 Mbps	—	-90	—	dBm
		11 Mbps	—	-85	—	dBm
	OFDM	6 Mbps	—	-88	—	dBm
		54 Mbps	—	-70	—	dBm

	HT20	MCS7	—	-67	—	dBm
--	------	------	---	-----	---	-----

4. Application Specification

4.1 Module Size

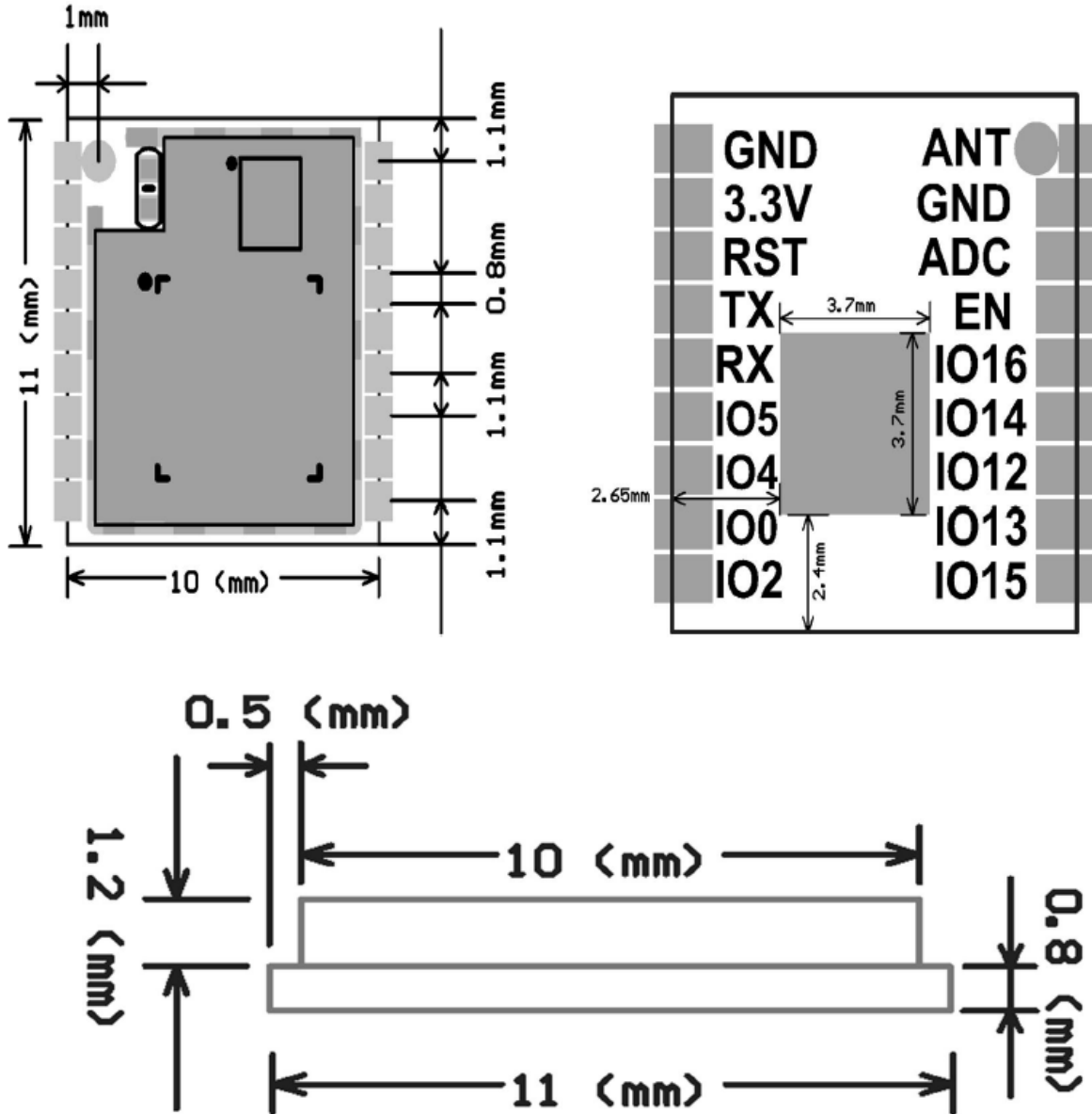
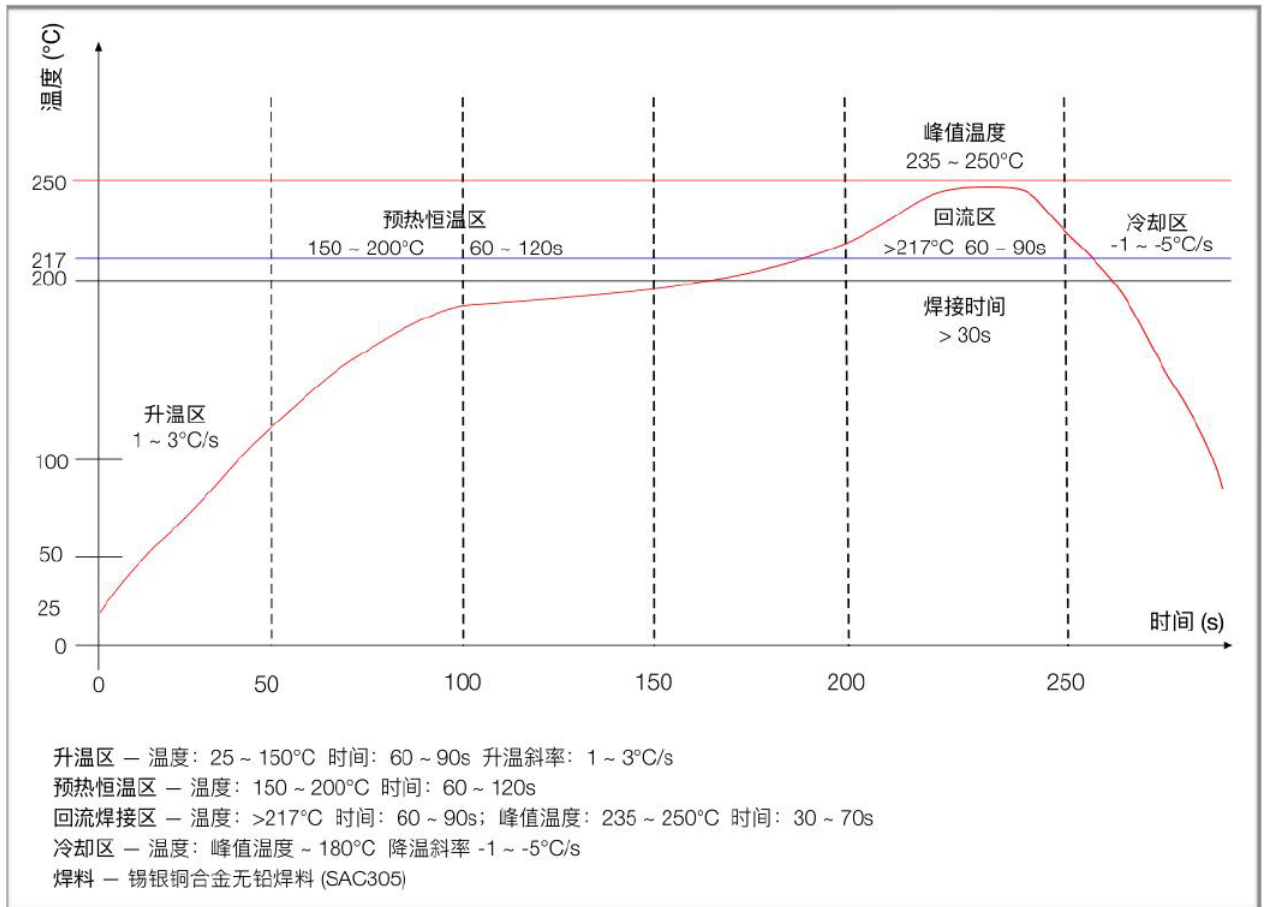

Figure -4 Module Size

4.2 Reflow Profile



4.3 Schematics

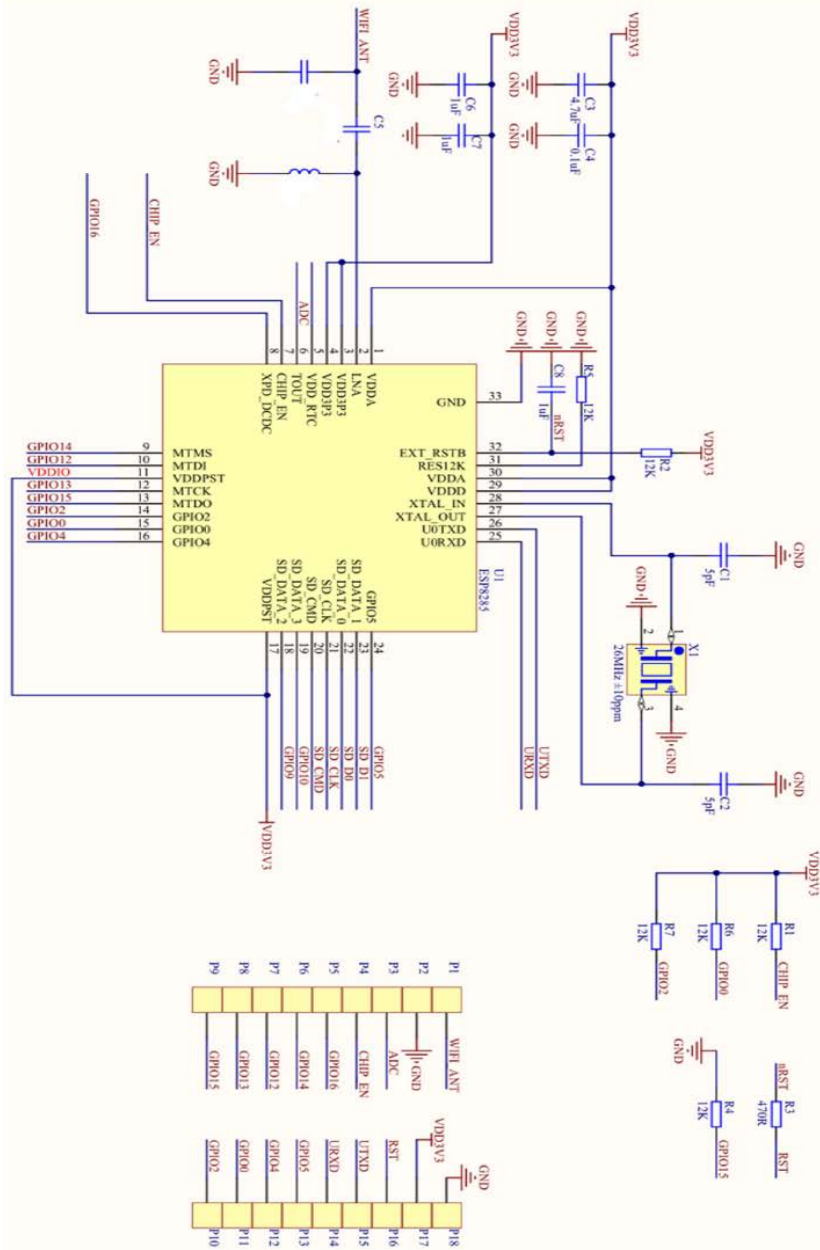

Figure -7 WT-01F Schematics

5. Certification

Figure -8RED (CE 0700) Certification

Figure -9FCC Certification

Figure -10 RoHSCertification

6. Product Trial

- Sales: sales@wirless-tag.com
- Technical Support : technical@wireless-tag.com